

## lifetime limited warranty

Your Drive brand product is warranted to be free of defects in materials and workmanship for the lifetime of the original consumer purchaser.

This device was built to exacting standards and carefully inspected prior to shipment. This Lifetime Limited Warranty is an expression of our confidence in the materials and workmanship of our products and our assurance to the consumer of years of dependable service.

In the event of a defect covered by this warranty, we will, at our option, repair or replace the device.

This warranty does not cover device failure due to owner misuse or negligence, or normal wear and tear. The warranty does not extend to non-durable components, such as rubber accessories, casters, and grips, which are subject to normal wear and need periodic replacement.

If you have a question about your Drive device or this warranty, please contact an authorized Drive dealer.



© 2006 Medical Depot, Inc. All rights reserved.  
Drive is a trademark of Medical Depot, Inc.  
Port Washington N.Y. 11050 USA Made in USA

plastic transfer bench



EU Authorized Representative  
Drive Medical LTD  
Ainley's Industrial Estate  
Elland, West Yorkshire,  
United Kingdom HX5 9JP

[www.drivemedical.com](http://www.drivemedical.com)

drive  
MEDICAL DESIGN & MANUFACTURING

[www.drivemedical.com](http://www.drivemedical.com)

drive  
MEDICAL DESIGN & MANUFACTURING

## assembly instructions

1. Remove contents from carton.
2. Lay transfer bench upside down on a flat surface.
3. Attach leg with the large suction cup (marked "1") by depressing the brass push pin and inserting into the receptacle with the matching "1". Repeat for second leg (Figure 1).



figure 1

4. Attach leg with small rubber tip (marked "2") by depressing brass push pin and inserting into the receptacle with matching "2". Repeat for second leg (Figure 2).

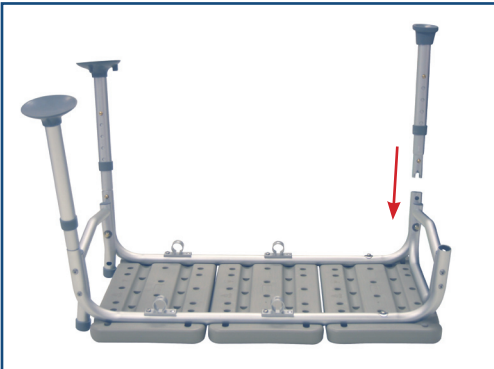

figure 2

5. Turn transfer bench right-side-up. Attach armrest by depressing brass push pins and sliding into the arm receptacle on the side of the bench. Make sure the arm arcs outward, not inward (Figure 3).



figure 3

6. To assemble backrest, insert pole into backrest support by depressing push pin and sliding into receptacle. Repeat for second pole (Figure 4).

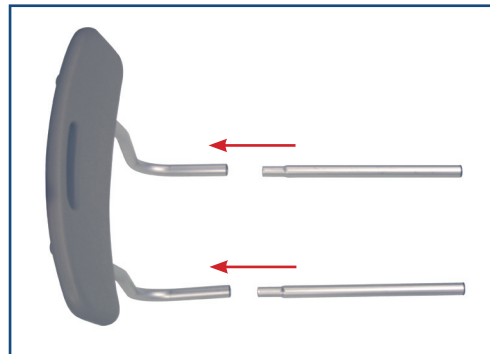

figure 4

6. Insert backrest into base by depressing push pins and sliding supports through both receptacles. Note: backrest must go through both sets of receptacles to become secure (Figure 5).



figure 5

NOTE: Back support is reversible to accommodate left or right tub entry. You can also change the seat depth of your transfer bench by pushing the pins under the seat and sliding the tubes forward until the pins lock into place.

7. Place legs with suction cups into bath tub.



12011KD-2 Shown